



Design Guide

Sealed Burner Rangetops (SRT)

ICB REVISED 4/2023



Sealed Burner Rangetops

Wolf Sealed Burner Rangetops incorporate all the gas cooking features of a Wolf Dual Fuel Range. Customize your rangetop with your preferred combination of burners, infrared griddle, charbroiler, or wok burner. All Sealed Burner Rangetop models are constructed of stainless steel and can be ordered in natural or LP gas.

Features and specifications are subject to change at any time without notice.

Throughout this guide, dimensions may vary by ± 3 mm.

CONFIGURATIONS

91 cm RANGETOP

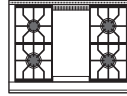

ICBSRT364G

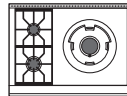

ICBSRT362W

122 cm RANGETOP

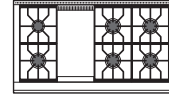

ICBSRT486G

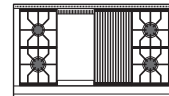

ICBSRT484CG

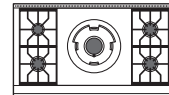

ICBSRT484W

Sealed Burner Rangetops

Sealed Burner Rangetops

91 cm RANGETOP

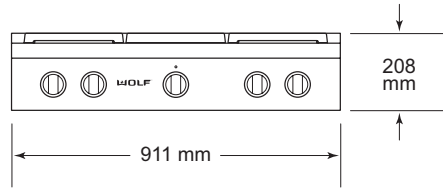

122 cm RANGETOP

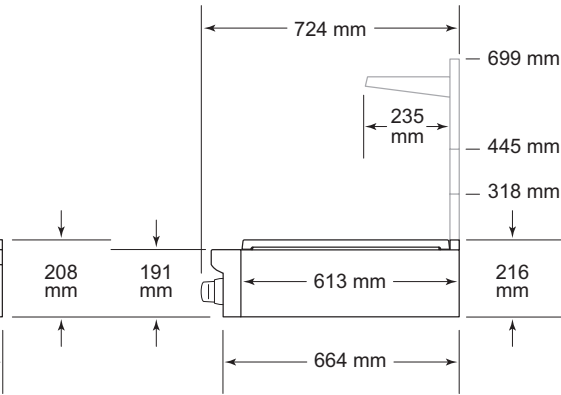
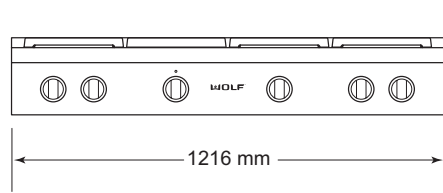

SIDE VIEW—ALL RANGETOPS

Planning Information

The platform to support the Sealed Burner Rangetop must include a cutout for electrical and gas supply connections. Refer to the chart below for minimum base support.

When installing against a combustible surface, a minimum 254 mm riser is required for 91 cm and 122 cm Sealed Burner Rangetops with a charbroiler or griddle. Follow all minimum clearances to combustible surfaces shown in the illustration on the following page. Models ICBSRT362W and ICBSRT484W cannot be installed against a combustible surface.

INSTALLATION REQUIREMENTS

PLATFORM	
Thickness	19 mm
BASE SUPPORT	
	MIN
91 cm Rangetop	113 kg
122 cm Rangetop	136 kg

ELECTRICAL REQUIREMENTS

Installation must comply with all applicable electrical codes and be properly grounded (earthed).

Locate the electrical supply within the shaded area shown in the illustration on the following page.

ELECTRICAL REQUIREMENTS

Electrical Supply	grounded, 220-240 VAC; 50/60 Hz
Service	0.2 A
Receptacle	grounding-type (earthed)
Power Cord	2 m

GAS SUPPLY

Installation must conform with all applicable gas codes.

A gas supply line of 19 mm rigid pipe should be provided to the rangetop. If local codes permit, a certified, .9 m long, 13 mm or 19 mm ID flexible metal appliance connector is recommended to connect the units ISO 7/1-14 female inlet to the gas supply line.

GAS REQUIREMENTS

NATURAL GAS		WC
Max. Supply Pressure		2.5 kPa
LP GAS		WC
Max. Supply Pressure		3.7 kPa

Sealed Burner Rangetops

Sealed Burner Rangetop

INSTALLATION

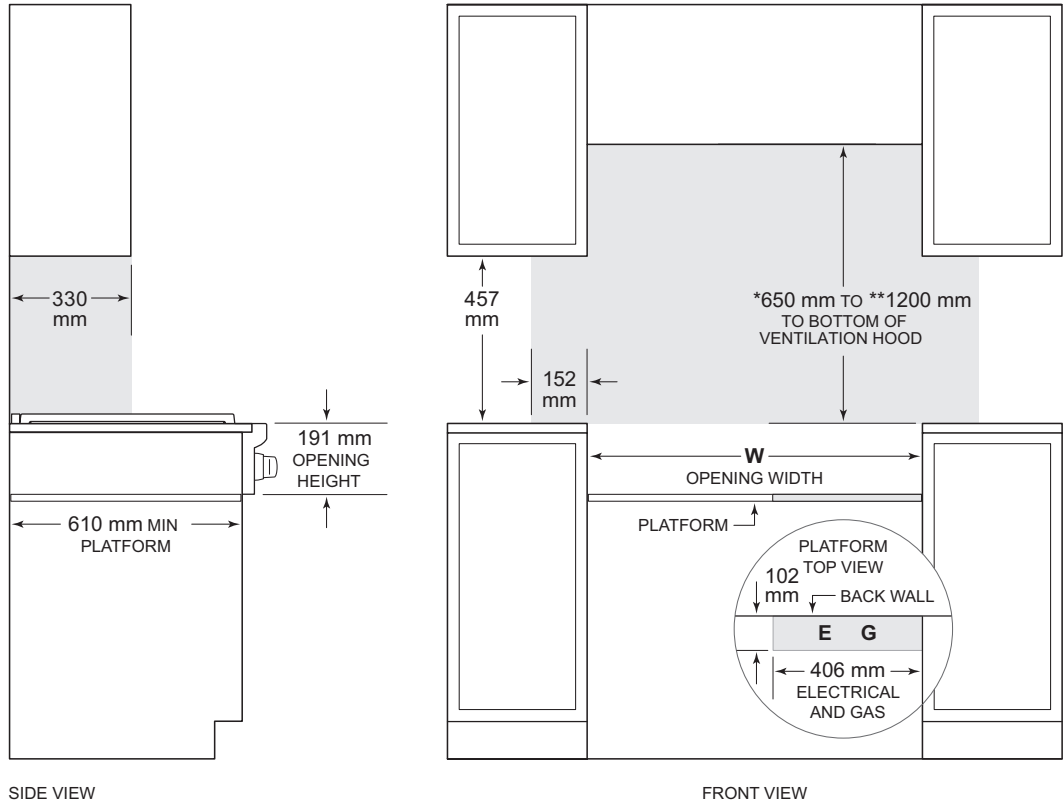

* A minimum clearance of 650mm from the top of the trivet to the range hood/combustible surface.
 Where the range hood manufacturer advises a higher clearance than 650mm then this must be used.
 **For models with chargrill burner a minimum clearance of 1200mm to the filter/combustible surface from the top of the chargrill trivet is required as per Australian standards.

OPENING WIDTH	W
91 cm Model	914 mm
122 cm Model	1219 mm

Wolf Appliance International Limited Warranty

FOR RESIDENTIAL USE

These Warranty Terms and Conditions ('Warranty') constitute your agreement with Sub-Zero Group Australia Pty Ltd (ACN 610 807 899) ('Wolf') and will apply to your service order. The benefits given by this Warranty are in addition to all consumer guarantees and other rights and remedies prescribed by the Australian Consumer Law and any other applicable laws.

Our products come with guarantees that cannot be excluded under the Australian Consumer Law. You are entitled to a replacement or refund for a major failure and compensation for any other reasonably foreseeable loss or damage. You are also entitled to have the goods repaired or replaced if the goods fail to be of acceptable quality and the failure does not amount to a major failure.

In addition to your rights and remedies under the Australian Consumer Law, Wolf provides customers with a Warranty where, if any part of a Wolf product is found upon inspection by an authorised Wolf representative or an associated licensed technician supplied by either Wolf or a relevant approved supplier (including a Wolf factory certified service) ('Service Representative') to be defective in materials or workmanship, Wolf will repair and replace the part as follows:

FULL TWO YEAR WARRANTY* (**Outdoor product full one year warranty)

For two years from the date of original installation, this Wolf Appliance product warranty covers all parts and labour to repair or replace, under normal residential use, any part of the product that proves to be defective in materials or workmanship. All service provided by Wolf Appliance under the above warranty must be performed by Wolf factory certified service, unless otherwise specified by Wolf Appliance, Inc. Where the Service Representative is unable to identify any fault in the product, Wolf may require the consumer to provide proof that the product is defective. For the avoidance of doubt, defective products or parts become Wolf's property. Service will be provided during normal business hours.

LIMITED FIVE YEAR WARRANTY

For five years from the date of original installation, Wolf Appliance will repair or replace the following parts that prove to be defective in materials or workmanship: gas burners (excludes appearance), electric heating elements, blower motors (ventilation hoods), electronic control boards, magnetron tubes and induction generators. If the owner uses Wolf factory certified service, the service provider will repair or replace the above listed parts at no cost with the owner paying for all other costs, including labour. If the owner uses non-certified service, the owner must contact Sub-Zero Group Australia, (using the information below) to receive repaired or replacement parts. Wolf Appliance will not reimburse the owner for parts purchased from non-certified service or other sources.

TERMS APPLICABLE TO EACH WARRANTY

The warranty applies only to products installed for normal residential use. This warranty does not cover any parts or labour to correct any defect caused by negligence, accident or improper use, maintenance, installation, service or repair.

CLAIM PROCEDURE

In order to claim the Warranty, you must cease using the product when a fault arises, contact Sub-Zero or authorised Sub-Zero dealer where the product was purchased to report the issue and follow Sub-Zero's directions regarding what to do next. Sub-Zero's general contact details are as follows:

Sub-Zero Group Australia
11-19 Bank Place
Melbourne VIC 3000
Phone: 03 9600 2218 email: serviceAU@subzero.com

EXCLUSIONS

Except to the extent required by law, all consumer guarantees, representations, warranties, terms and conditions in relation to the products (whether implied or otherwise) are hereby excluded to the maximum extent permitted by law.

To the fullest extent permitted by law, Wolf excludes all liability for damage or injury to any person, damage to any property and any indirect consequential or other loss or damage.

*Stainless steel (doors, panels, handles, product frames and interior surfaces) are covered by a limited 60-day parts and labour warranty for cosmetic defects.

** Full one year warranty applies to outdoor product. Product must be approved for outdoor use, designated by model and serial number.



